

95X95 MM GYPSUM MOUNTING PLATFORM

DRYWALL, PLASTER, & WALLPAPER

DESCRIPTION:

Applications:

Gypsum mounting platforms are designed for wall installations and they contain an integrated back mounting bracket that seamlessly integrates the Black Nova or Lutron Palladiom I Column Euro size devices into the TRUFIG mounting system. The mounting platforms are available in panel thicknesses of 1/2" and 5/8" and for a variety of wall plaster, and wallpaper.

Flush Finish:

Platform technology allows for a zero-sightline, flush finish. Paint-ready Fascias provide flexible finishing options including paints and veneers.

Fascias/Devices:

Accepts TRUFIG fascia for Lutron Palladiom I Column Euro size.

Also Accepts Black Nova 95 mm keypad.

Accessories:

Plaster shims - adjusts the mud dam in 1/16" increments to accommodate up to 3/8" plaster thickness.

TECHNICAL:

Materials:

Panel -Pressed Gypsum (fire class A, 95% recycled material) material is impact, mold and moisture resistant.

Enclosure - 18 GA Galvanized Steel.

Mud Dam - Precision Machined Aluminum

Environment:

For indoor use only - mounting platform can be used in damp locations such as kitchens, back-splashes, and bathrooms.

ORDERING INFO:

95X95 5/8 GYPUM MOUNTING PLATFORM Model#: 51240

95X95 12 GYPSUM MOUNTING PLATFORM Model#: 51241

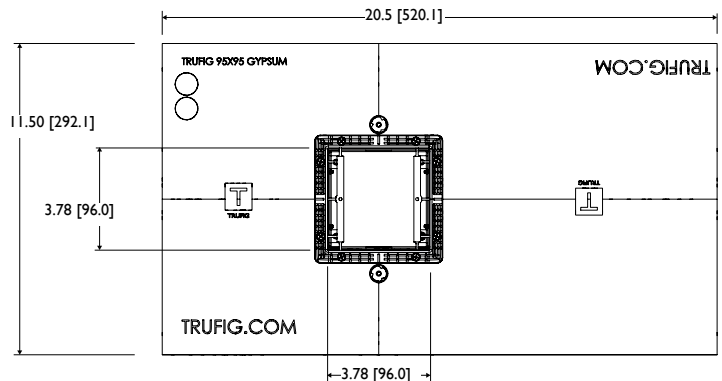
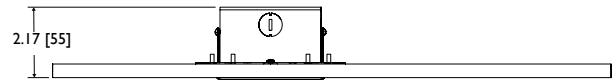
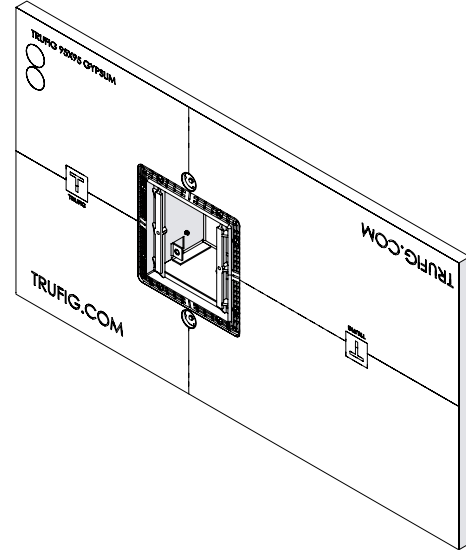

991 Calle Amanecer
San Clemente, CA. 92673
(949) 492-7777

As part of its policy of continuous research and product development, the company reserves the right to change or withdraw specifications without pryor notice,

TRUFIG and the TRUFIG Logo are trademarks of Dana Innovations. © 2017 Dana Innovations. All rights reserved.



TYPE:

CATALOG:

PROJECT:

DATE:

TRUFIG.COM