

95X95 MM SOLID SURFACE MOUNTING PLATFORM

INSTALLATION SOLID SURFACE MOUNTING PLATFORM - STONE, WOOD, GLASS & OTHER SOLID SURFACES

DESCRIPTION:

Applications:

Solid surface mounting platforms are designed for wall installations and they contain an integrated back mounting enclosure that seamlessly integrates the Black Nova or Lutron Palladiom I Column Euro size devices into the TRUFIG mounting system. The mounting platforms are available in 1/2" and 5/8" thicknesses and for a variety of wall coverings tile. The platform can accommodate solid surface materials from 3/8 to 1-1/4" thick.

Flush Finish:

Platform technology allows for a zero-sightline, flush finish. Paint-ready Fascias provide flexible finishing options including paints and veneers.

Fascias/Devices:

Accepts TRUFIG fascia for Lutron Palladiom I Column Euro size.

Also Accepts Black Nova 95 mm keypad.

Accessories:

Router Template - quickly and precisely route Fascia opening in the field with a rigid Plexiglas router template
Plaster shims - adjusts the mud dam in 1/16" increments to accommodate up to 3/8" plaster thickness

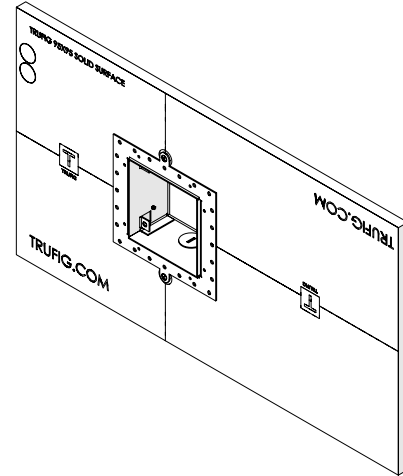

TECHNICAL:

Materials:

Panel - Pressed Gypsum (fire class A, 95% recycled material) material is impact, mold and moisture resistant.

Enclosure - 18 GA Galvanized Steel.

Environment:

For indoor use only - mounting platform can be used in damp locations such as kitchens, back-splashes, and bathrooms.

ORDERING INFO:

95x95 5/8 SOLID SURFACE MP	51242
95X95 1/2 SOLID SURFACE MP	52243

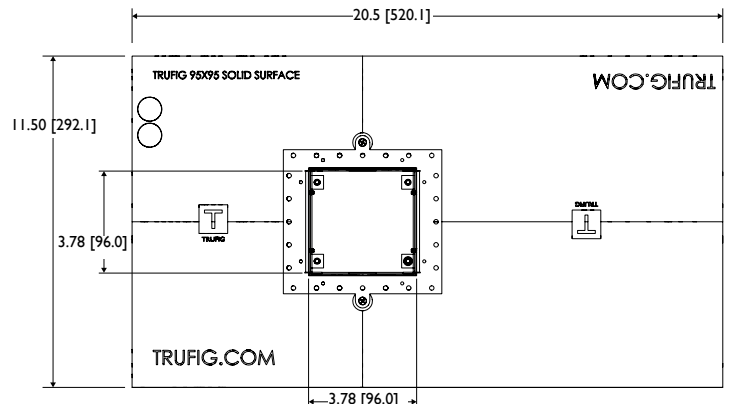

991 Calle Amanecer
San Clemente, CA. 92673
(949) 492-7777

As part of its policy of continuous research and product development, the company reserves the right to change or withdraw specifications without prior notice.

TRUFIG and the TRUFIG Logo are trademarks of Dana Innovations. © 2017 Dana Innovations. All rights reserved.



TYPE:

CATALOG:

PROJECT:

DATE:

TRUFIG.COM