

KEYPAD ASSEMBLY BLACK NOVA 95X95MM

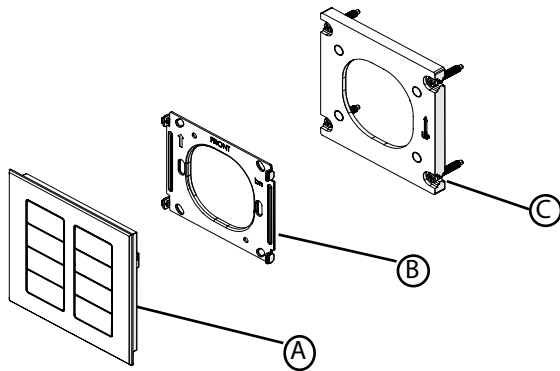

- (A) BLACK NOVA KEYPAD
NOT SUPPLIED
- (B) BLACK NOVA MOUNTING BRACKET
NOT SUPPLIED
- (C) TRIM COMPONENT

DESCRIPTION:

Applications:

This Trim Component can be used with the Black Nova Aria or Alba 95x95 mm.

Not supplied by TRUFIG

TECHNICAL:

Trim Component is made of ABS plastic.

Uses 4 Neodimium magnets to hold the Black Nova keypad in place.

This assembly can be used with any of the following Mounting Platforms:

MODEL #	DESCRIPTION
51240	95x95 5/8 IN GYP MP
51241	95x95 1/2 IN GYP MP
51242	95x95 5/8 IN SS MP
51243	95x95 1/2 IN SS MP

ORDERING INFO:

BLACK NOVA 95X95 MM TRIM COMPONENT Model#: 50338

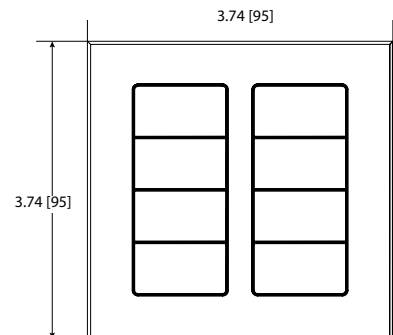
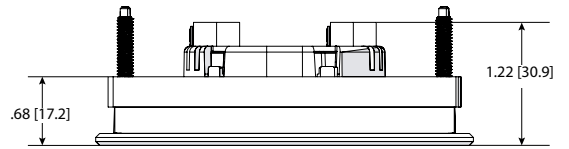

991 Calle Amanecer
San Clemente, CA. 92673
(949) 492-7777

As part of its policy of continuous research and product development, the company reserves the right to change or withdraw specifications without prior notice.

TRUFIG and the TRUFIG Logo are trademarks of Dana Innovations. © 2017 Dana Innovations. All rights reserved.



TYPE:
CATALOG:
PROJECT:
DATE:

TRUFIG.COM